

FLOOD/FREE



Protect your property, assets and livelihood with proven, Australian made, Flood Barriers.

DESIGNED AND MANUFACTURED BY

awma
Water Control Solutions



INTRODUCTION

FloodFree offer a proven range of purpose-built Flood Barriers, designed and manufactured in Australia by AWMA Water Control Solutions.

The FloodFree Barrier range consists of four key products:

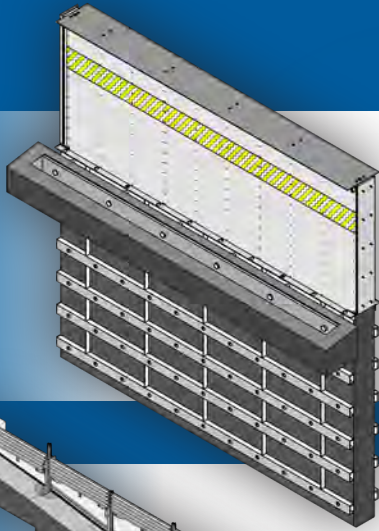

**CONCEALED
FLOOD BARRIER**

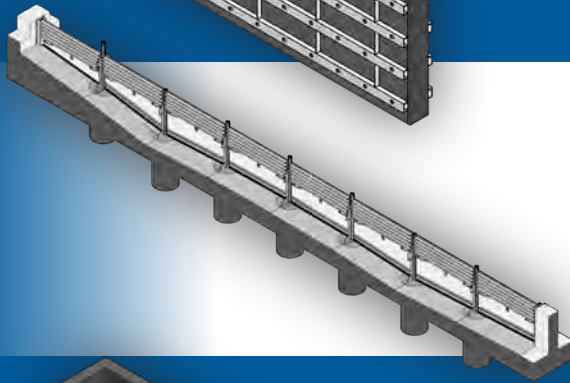
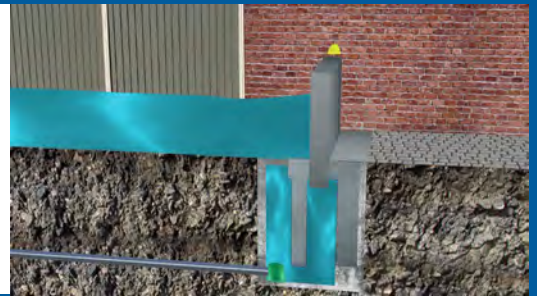

**DEMOUNTABLE
FLOOD BARRIER**

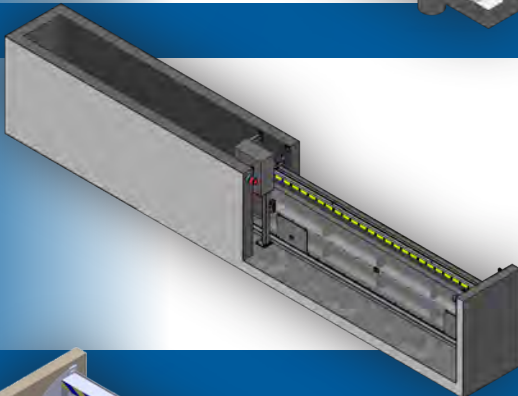

**RETRACTABLE
FLOOD BARRIER**

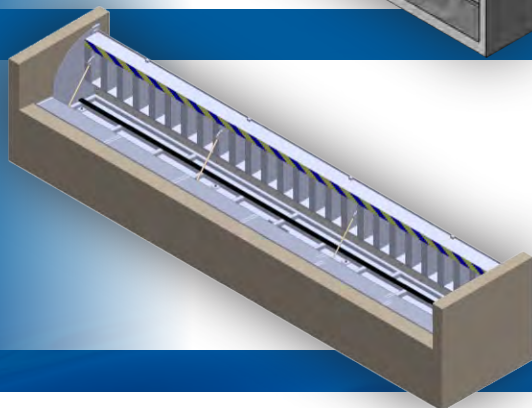

**TILTING FLOOD
BARRIER**

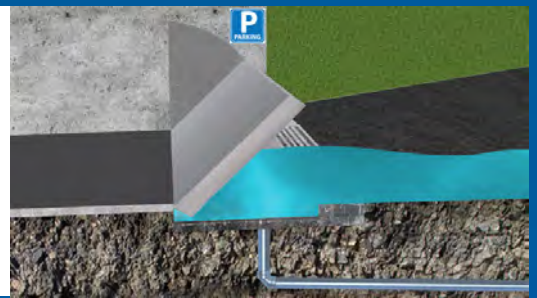



CONTENTS

| | |
|---------------------------------|----|
| INTRODUCTION | 2 |
| APPLICATIONS | 3 |
| CONCEALED FLOOD BARRIER | 4 |
| DEMOUNTABLE FLOOD BARRIER | 6 |
| RETRACTABLE FLOOD BARRIER | 8 |
| TILTING FLOOD BARRIER | 10 |

APPLICATIONS

FloodFree barrier designs have been accepted by councils Australia-wide with installations including:

- Underground car parks
- Pedestrian access and pathways
- Driveways
- Asset protection
- Building entrances
- Flood Levees
- Basements

CONCEALED FLOOD BARRIER

The Concealed Flood Barrier is self-actuating. Rising flood waters automatically deploy the barrier via floatation.



DEPLOYED



CONCEALED



FEATURES

The barrier is permanently installed below ground level at the isolation point, ready for deployment when required.

Rising water levels cause an automatic response, elevating the isolation barrier via floatation.

- Suitable for 1m-20m wide openings.
- Low maintenance design.
- Options available to meet aesthetic and traffic loading requirements.
- Minimal footprint.

DESIGN SUPPORT

All FloodFree Barriers are purpose-designed, engineered and manufactured by AWMA Water Control Solutions.

AWMA's design team provide full support to project partners, ensuring the product delivered will be engineered and certified to withstand worse case scenarios for expected flood water height, debris loading, deployment times etc.

Design considerations include the condition of the nominated site, with options for greenfield and brownfield sites.

MAINTENANCE

The FloodFree range has a minimum 25 year design life. Minimal maintenance is required ensuring low 'whole of life costs'.

QUALITY

All procedures are in accordance with AWMA's accredited ISO 9001 Quality Management System to ensure each barrier is manufactured to a high standard, tested and ready for trouble free operation.

OPERATION

The Concealed Flood Barrier uses approaching floodwaters to automatically raise the barrier without human intervention, electricity or mechanical assistance.

DOCUMENTATION

Detailed documentation on operation, testing procedures and maintenance can be provided with all FloodFree Barriers.

TRAINING

Comprehensive on and/or off site training available.

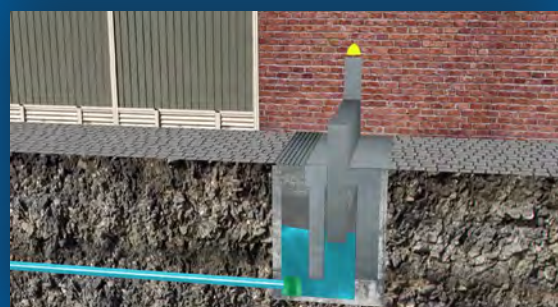
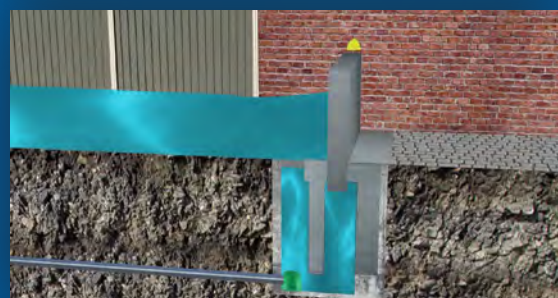
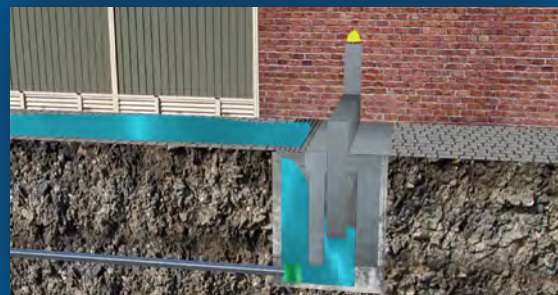
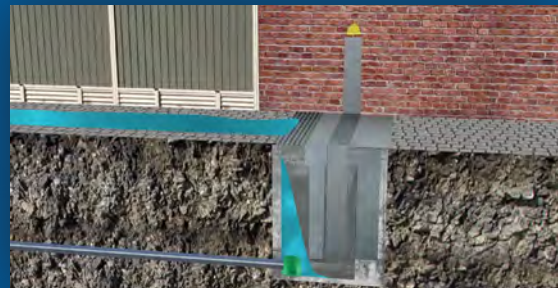

DEMOUNTABLE FLOOD BARRIER

Demountable Flood Barriers allow asset owners to manually deploy their own protection barriers to isolate flood and storm waters in and around existing infrastructure.

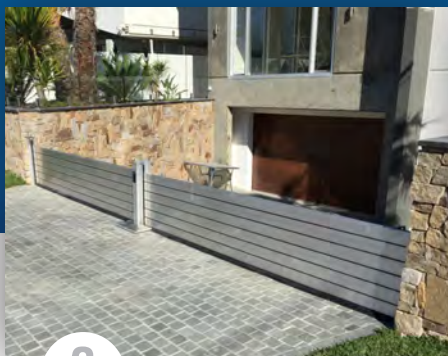

FEATURES

- Construct to an infinite length.
- Modular segments are fabricated in 100mm, 200mm or 300mm high increments.
- Segments consist of extruded section with embedded seals.
- Storage solutions and transportation trolleys available.
- Economically viable.

DESIGN SUPPORT

All FloodFree Barriers are purpose-designed, engineered and manufactured by AWMA Water Control Solutions.

AWMA's design team provide full support to project partners, ensuring the product delivered will be engineered and certified to withstand worse case scenarios for expected flood water height, debris loading, deployment times etc.

Design considerations include the condition of the nominated site, with options for greenfield and brownfield sites.

MAINTENANCE

The FloodFree range has a minimum 25 year design life. Minimal maintenance is required ensuring low 'whole of life costs'.

QUALITY

All procedures are in accordance with AWMA's accredited ISO 9001 Quality Management System to ensure each barrier is manufactured to a high standard, tested and ready for trouble free operation.

OPERATION

The Demountable Flood Barriers are designed to be manually deployed by one or two operators.

DOCUMENTATION

Detailed documentation on operation, testing procedures and maintenance can be provided with all FloodFree Barriers.

TRAINING

Comprehensive on and/or off site training available.



RETRACTABLE FLOOD BARRIER

The Retractable Flood Barrier is permanently installed within existing infrastructure then slides to seal large openings.

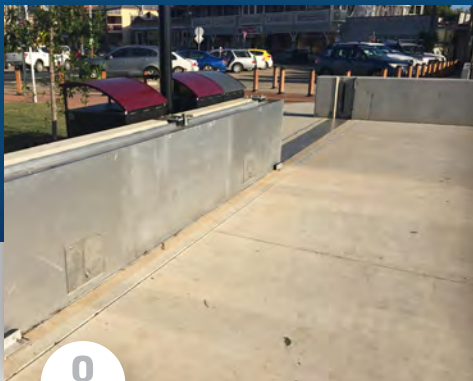

FEATURES

- Suitable for 1m - 30m wide openings up to 3m high as standard.
- Easily deployed by a single operator.
- Heal safe track system.
- Custom designed to meet site requirements.
- Low maintenance.
- Can be designed to complement building facades.

DESIGN SUPPORT

All FloodFree Barriers are purpose-designed, engineered and manufactured by AWMA Water Control Solutions.

AWMA's design team provide full support to project partners, ensuring the product delivered will be engineered and certified to withstand worse case scenarios for expected flood water height, debris loading, deployment times etc.

Design considerations include the condition of the nominated site, with options for greenfield and brownfield sites.

MAINTENANCE

The FloodFree range has a minimum 25 year design life. Minimal maintenance is required ensuring low 'whole of life costs'.

QUALITY

All procedures are in accordance with AWMA's accredited ISO 9001 Quality Management System to ensure each barrier is manufactured to a high standard, tested and ready for trouble free operation.

OPERATION

The Retractable Flood Barrier travels sideways to close the gap in an existing wall, completing the isolation required to protect assets from rising water levels.

DOCUMENTATION

Detailed documentation on operation, testing procedures and maintenance can be provided with all FloodFree Barriers.

TRAINING

Comprehensive on and/or off site training available.



TILTING FLOOD BARRIER

Tilting Flood Barriers are permanently installed, rising to a vertical position to isolate access areas from flood waters.



PASSIVE TILTING FLOOD BARRIERS

Operate on buoyancy principles to ensure the flood barrier automatically deploys, as flood waters rise, providing complete peace of mind.

POWERED TILTING FLOOD BARRIERS

Have the additional ability for PRE or POST inundation Flood Barrier Deployment; utilising level sensors for automatic deployment as well as the option to locally and/or remotely operate flood barriers when required, giving you complete control of your flood barriers.

FEATURES

- Tilting Flood Barriers may be Passive or Actuated.
- Fabricated from materials to suit site specifications.
- Low maintenance design.
- Fully trafficable.
- Excellent sealing.

DESIGN SUPPORT

All FloodFree Barriers are purpose-designed, engineered and manufactured by AWMA Water Control Solutions.

AWMA's design team provide full support to project partners, ensuring the product delivered will be engineered and certified to withstand worse case scenarios for expected flood water height, debris loading, deployment times etc.

Design considerations include the condition of the nominated site, with options for greenfield and brownfield sites.

MAINTENANCE

The FloodFree range has a minimum 25 year design life. Minimal maintenance is required ensuring low 'whole of life costs'.

QUALITY

All procedures are in accordance with AWMA's accredited ISO 9001 Quality Management System to ensure each barrier is manufactured to a high standard, tested and ready for trouble free operation.

OPERATION

Tilting Flood Barriers are engineered to ensure automatic deployment ahead of flood waters.

DOCUMENTATION

Detailed documentation on operation, testing procedures and maintenance can be provided with all FloodFree Barriers.

TRAINING

Comprehensive on and/or off site training available.

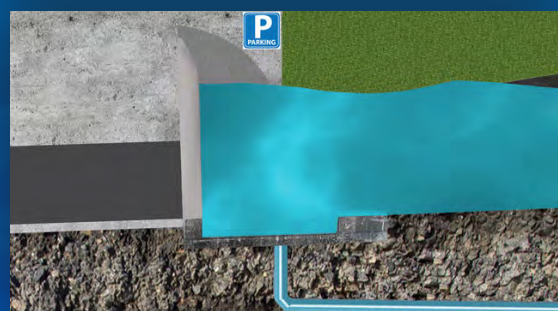
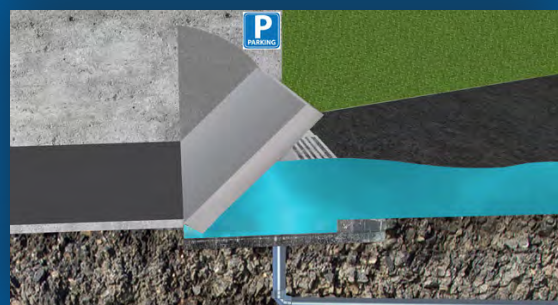
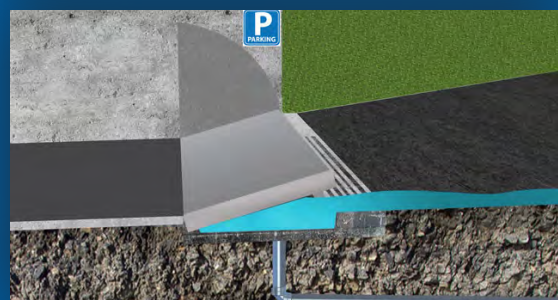
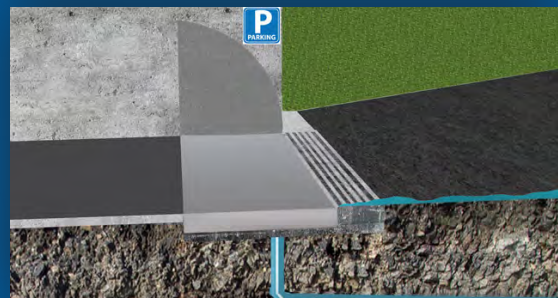
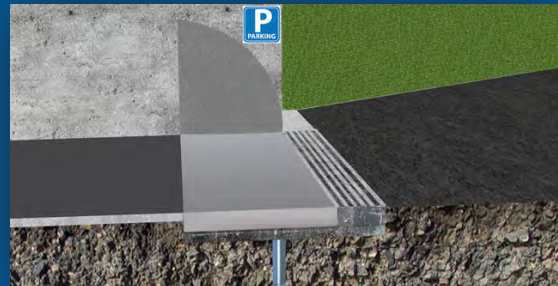



CONCEALED FLOOD BARRIER

DEMOUNTABLE FLOOD BARRIER

RETRACTABLE FLOOD BARRIER

TILTING FLOOD BARRIER

DESIGNED AND MANUFACTURED BY



Phone +61 3 5456 3331 Email info@awmawatercontrol.com.au
118 Roviras Road, PO Box 433, Cohuna Victoria 3568, Australia.
www.awmawatercontrol.com.au

